



**PICKUP TRUCK SNOWPLOW
C-PLOW
MODEL 3800**

OPERATOR'S MANUAL

DO NOT USE OR OPERATE THIS EQUIPMENT UNTIL THIS MANUAL
HAS BEEN READ AND THOROUGHLY UNDERSTOOD

PART NUMBER 25010924 Rev A



TABLE OF CONTENTS

25010924 Rev A

6/02

E:1054-C-Plow-#1001(840)

TO THE PURCHASER	2
SAFETY	3
OPERATING PROCEDURES	4
TROUBLE SHOOTING	10
MAINTENANCE	12
ASSEMBLY	14
SPECIFICATIONS	24
WARRANTY	Inside Rear Cover

TO THE PURCHASER

This product is designed and manufactured to give years of dependable service when properly maintained and used for the purpose for which it is intended. Never allow anyone to operate this equipment until they fully understand the complete contents of this manual. It is the responsibility of owners who do not operate this equipment to ensure the operator is properly instructed and understands the contents of this manual. It is also the owner's responsibility to ensure that anyone operating this equipment is mentally and physically capable of so doing.

Important information is contained in this manual to help ensure safe and efficient operation.

If you have any questions about this manual, or the equipment discussed herein, contact your Hiniker dealer.



This is a safety alert symbol. It alerts an operator to information concerning personal safety. Always observe and heed these instructions, otherwise death or serious injury can result.

All references to Left or Right are defined as viewing the plow from the cab of the truck.

This Operator's Manual is shipped with this equipment. Contact your Hiniker dealer for additional copies.

Always obtain original Hiniker service parts. Substitute parts could adversely affect equipment performance and warranty.

Check that your dealer has forwarded the Hiniker delivery report form along with the plow identification number because it helps maintain maximum service and warranty benefits. This does not put you on any mailing list, and information thereon is not available to others.

Your plow's identification number decal is at location (1) in the following illustration.

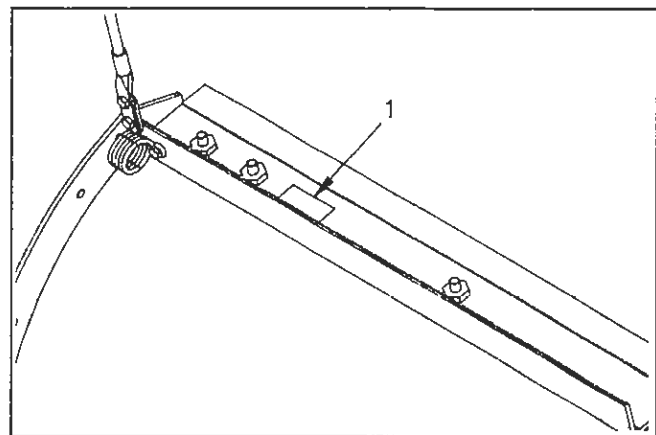

DWG. NO. 3918

Record the following information for later reference when obtaining service parts:

Purchase Date _____

Purchaser's Name _____

Dealer's Name _____

Machine I.D. No. _____

SAFETY



This is a safety alert symbol. It alerts an operator to information concerning personal safety. Always observe and heed these symbols and instructions, otherwise death or serious injury can result.

Operator safety is a principle concern in equipment design and distribution. However, many accidents occur because a few seconds of thought, and a more careful approach to handling, were ignored.

Accidents can be avoided by knowing and following the precautions cited in this manual.

GENERAL SAFETY

1. Read this manual thoroughly. Make sure the operator understands it and knows how to operate this equipment safely. This equipment can kill or injure an untrained or careless operator and bystanders. If you sell this equipment, ensure the new owner acknowledges receipt of this manual.
2. This plow is intended for plowing snow only. Plowing gravel, rocks, etc., or using the plow for any purpose other than plowing snow could result in harm to the operator or bystanders or cause damage to the plow or vehicle.
3. Do not attempt to handle or service this equipment, or direct others to do the same, unless you know how to do it safely and have the proper tools for the job.
4. Keep hands, feet, hair, and clothing away from moving parts.
5. Do not alter the equipment to the extent of compromising safety or performance.

BEFORE OPERATION

1. Discipline yourself to visually check for worn, damaged or cracked parts before starting use. Replace these with genuine Hiniker parts.

2. Escaping hydraulic oil under pressure can penetrate the skin, causing serious injury.

Do not use your hand to check for leaks. Use a piece of paper or cardboard to find suspected leaks.

Tighten all connections before pressurizing hydraulic lines.

If fluid is injected into the skin, get medical attention immediately to prevent serious infection.

3. Check all controls and operating functions of the machine in a safe area before starting to work.

DURING OPERATION

1. Always wear seat belts when operating a motor vehicle.
2. Ensure everyone is clear of the machine, especially away from blind areas of the operator, before starting, actuating hydraulics or operating this equipment.
3. Do not plow snow at excessively high speeds.
4. Avoid hitting objects that will damage your plow or truck.
5. Set the brakes and stop the truck's engine before adjusting or servicing your plow. Do not service or otherwise handle a plow in the raised position unless it is securely blocked against unexpected falling.

AFTER OPERATION

1. Park the plow on a solid, level surface. Fully collapse the lift cylinder with the upper lift links before unhitching the plow to prevent the plow frame from falling forward.

OPERATING PROCEDURES

ATTACHING THE PLOW

Attachment prongs on the truck should be mounted such that the bottom edge of the prongs measure about 10 inches above the ground. Prong receivers on the plow frame should remain parallel to the ground and at the correct height by fully retracting the lift cylinder with the upper lift links before removing the plow from the truck (see "Removing the Plow"). Ideally, the prongs on the truck should lift the plow frame slightly when driving into the plow for attachment.

Powdered graphite applied on the prongs will help the plow slide on and off more easily.

Check that prongs are in line with the receivers before slowly driving into the plow. Set the parking brake in the truck to prevent it from creeping back out from the receivers.

Pull the latch handle into the clevis on the lift frame to force the sliders through the notches in the prongs and receivers. Pin the handle in the clevis with its klik pin. Failure to pin the handle in place may allow the plow to fall off the truck.

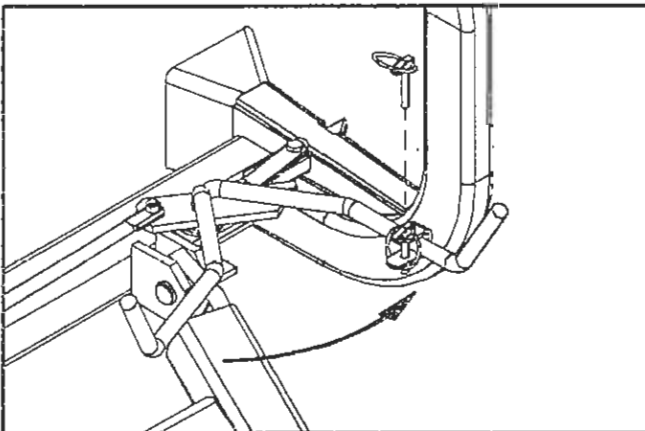

Handle Pinned With Plow On Truck

DWG. NO. 4199

Remove the tab lock pin from the parking stand index plate to raise the stand to its highest position. Reinstall the pin in the plate for transport.

NOTE: Before connecting the plow's wiring to the truck, make sure power is switched "Off" on the joystick controller.

Plug in the three electrical connectors between the plow and the truck after latching the plow. The alignment tab on the 10-pin receptacle will mate with the slot in the mounting plate on the truck grill to ensure proper connection.

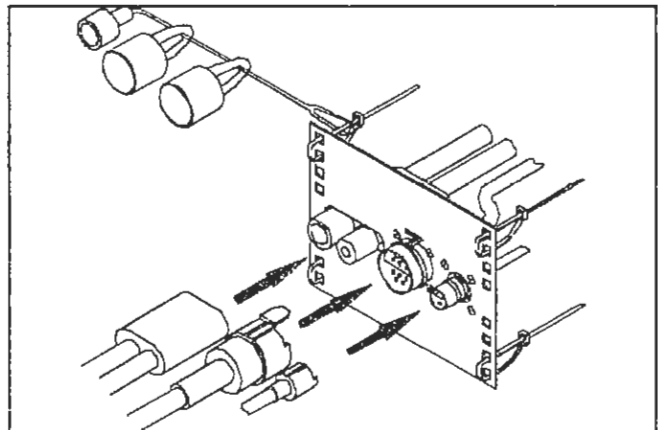

Alignment Tab and Slot

DWG. NO. 4192

Check that the plow headlamps and turn signals are operational, and headlamps are aimed correctly. Test the lift, angling and rollover functions in a safe area before using the plow.

To make alignment of the plow easier in the future, mark a point on the back of the head lamp, a point on the hood near the front of the truck and a point on the windshield that are in line when you are seated behind the steering wheel. Line up these three points when driving into the plow.

THE JOYSTICK CONTROLLER

The joystick control box has slide switches for controlling power to the snowplow and for switching from the truck headlights to the headlights on the plow.

The joystick controls the left and right angling functions of the snowplow, and also controls the raising and lowering of the plow. Two push button switches are used to curl and uncurl the plow blade.

The vehicle's electrical power must be turned on before the control box will function.

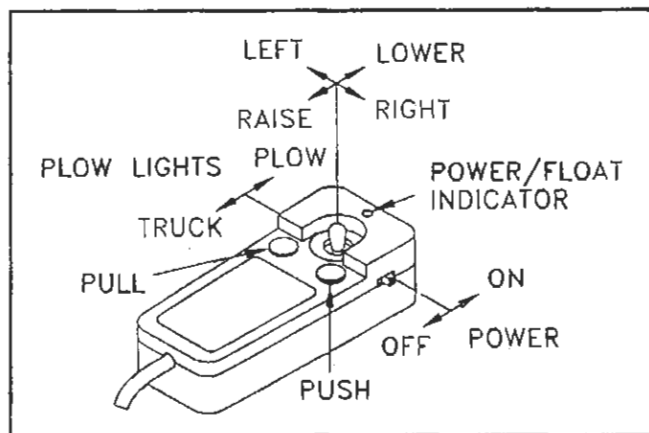

Joystick Control Box

DWG. NO. 4162

Place the on/off switch on the joystick control box in the "On" position to supply power to the snowplow. A green light will indicate power is on.

Move the headlight slide switch on the control box to the "Plow" position to change from the truck lights to the snowplow lights. Activate high beam/low beam and turn signal/parking lamps from the truck as you normally would without the plow attached.

NOTE: When removing the plow, remember to place the headlight switch in the "Truck" position to return power to the truck's headlights.

Raise or lower the plow by moving the joystick controller to the "Raise" or "Lower" position. Hold the plow at an intermediate height by releasing the controller from the "Raise" position when the plow reaches the desired height. Moving the controller to the "Lower" position will lower the blade to the ground and allow the plow to "float" along the contour of the ground while plowing snow.

The green light on the control box will turn yellow to indicate the plow is in the float mode. Momentarily moving the joystick to the "Raise" position will remove the plow from the float condition and the yellow indicator will return to green.

Move the joystick controller left or right to angle the blade. Release the joystick when the blade is at the desired angle.

Curl the plow blade forward by pushing the left hand button on the control box. Uncurl the blade by pushing the right hand button. Release the button to hold the blade at an intermediate position between full forward or full back. The blade will move more freely if the curl and uncurl functions are done with the plow in the raised position to avoid resistance from the ground.

TRANSPORTING THE PLOW

The extra weight of the snowplow on your truck will impair handling response and increase braking distance. The plow will also block some airflow to the vehicle's cooling system, possibly causing the vehicle to overheat. Therefore, it is important not to exceed speeds above 45 mph when the plow is attached. Remove the plow if you must drive your truck for long distances when the temperature is warm.

Raise the blade to a position where it will not interfere with the headlights before driving. Transport the plow with power to the joystick control box switched off to prevent accidental lowering of the plow. Never adjust the blade height or angle the blade while driving.

PLOWING SNOW



WARNING: Always wear a seat belt when plowing snow. Sudden contact with a hidden object can result in serious personal injury.

Inspect areas to be plowed before snowfall for potential hazards, and mark obstructions with stakes that will be seen when snow covers the ground. Identify any emergency equipment and utility outlets that may need to be cleared in the event of a storm. Prepare a plan beforehand for clearing snow from tight or enclosed areas and locate sites for stacking snow.

Adjust the skids at the back of the moldboard according to the surface to be plowed. The bottom of the skids should be about 1/2" below the cutting edge when plowing gravel roads or lots. Skids should be even with the cutting edge on hard surfaces such as asphalt or concrete.

Always plow snow as it is accumulating. Wet snow may weigh about 12 pounds per cubic foot. The weight of snow being pushed by your plow may increase to several tons.

Allowing snow depth to grow to unmanageable levels can cause difficult removal problems and can be costly in terms of wear on equipment.



WARNING: Serious personal injury can result from plowing at excessive speeds, as well as costly damage to equipment and property, if an obstruction is encountered while plowing. Do not exceed 10 mph while plowing.

Plow snow in the lowest truck gear to transfer maximum power to the cutting edge. Clear areas in front of buildings first.



CAUTION: Prevent premature wear or damage to the plow by only backdragging snow with the plow blade straight across the truck. Do not angle the plow when upper edge is rolled over for pulling snow.

To backdrag snow away from a building, straighten the plow across the truck then lower the blade to the ground. Curl the upper edge forward with the LH controller button until the upper cutting edge touches the ground.

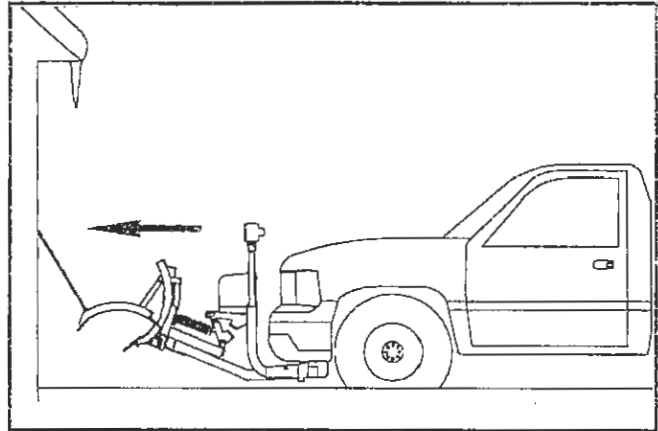

DWG. NO. 3850

Lift the plow with the joystick controller, then slowly drive to the building until the markers touch. Shift the vehicle transmission to neutral.

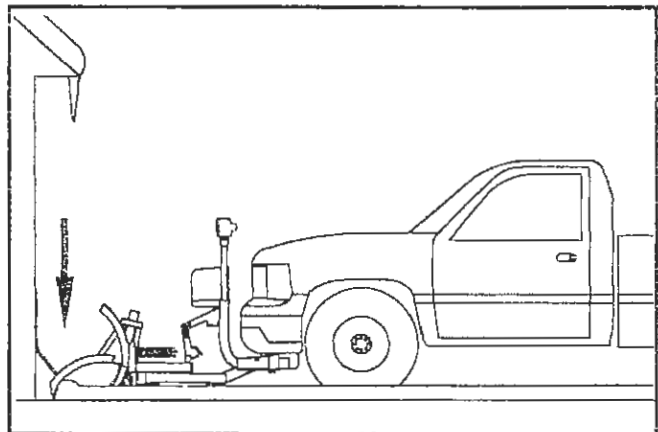

DWG. NO. 3851

Lower the plow to the ground with the joystick controller.

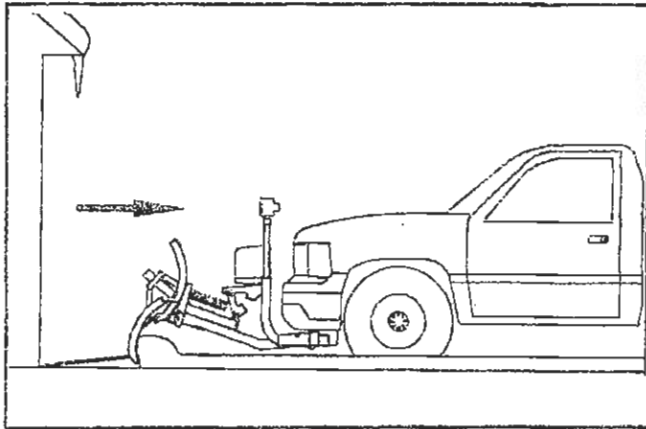

DWG. NO. 3852

Curl the plow fully forward with the LH controller button. Shift the vehicle transmission into reverse and pull snow away from the building.

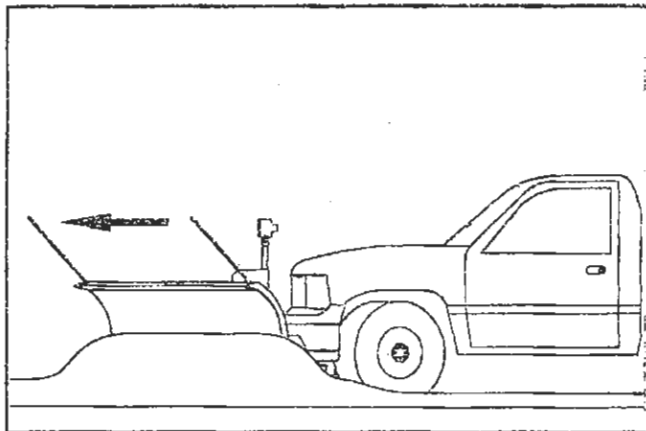

DWG. NO. 3853

Uncurl the plow with the RH controller button and push snow to a clear area.

Clear large lots by angling the blade and creating a single path. Push snow to outer edges of the lot by taking successive passes with the blade angled.

When plowing very deep snow, it may be necessary to raise the blade and shear off layers of snow until a working area is cleared. Work small areas in multiple passes to push snow to outer edges. Generally, 6 inch snow can be plowed with the entire blade width; 9 inch snow with 3/4 of the blade width; 12 inch snow the 1/2 of the blade width. Local conditions will determine how much work can be done before stalling or getting stuck.

PLOW END WINGS (OPTIONAL)

Use end wings on the plow to capture more snow when backdragging or pushing with the plow.

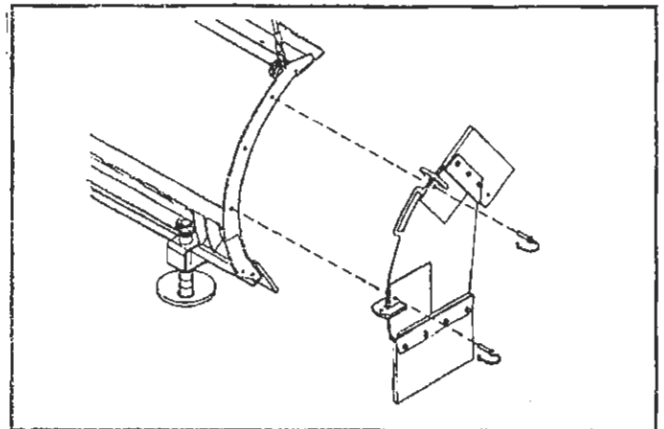

DWG. NO. 3849

Place wings over end ribs with holes aligned, then insert snap pins to attach wings.

Wings accommodate the curling motion of the C-Plow.

REMOVING THE PLOW

Lower the plow to the ground when parking your truck for a long period of time with the plow attached. Place the on/off switch in the "off" position to prevent the plow from drawing power from the truck battery. The plow's power unit may continue to draw electrical current from the truck battery if the control switch is left on; possibly resulting in insufficient charge to start the truck.

To remove the snowplow from your truck, park the truck on a solid level surface with the blade straight or angled slightly to the right. Lower the plow to the ground and leave the controller in the "float" mode.

NOTE: The plow control box must be in the "float" mode to move the cylinder rod. If the cylinder rod does not retract with power on and the controller in float, loosen the packing nut on the lift cylinder up to 1 1/2 turns to reduce friction.

B Operating Procedures

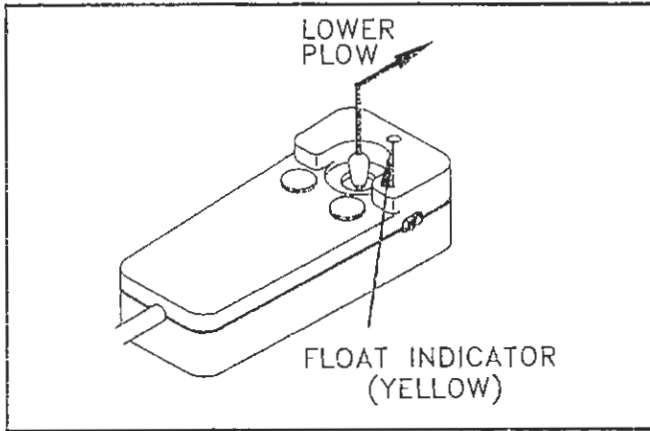

Lower Plow, Leave Controller in 'Float' DWG. NO. 4163

At the front of the truck, push down on the upper lift links to fully retract the lift cylinder rod. Retracting the lift cylinder will orient the prong receivers correctly for reattaching the plow later. Failure to retract the lift cylinder rod will allow the lift frame to fall forward, possibly causing personal injury or damage to plow components.

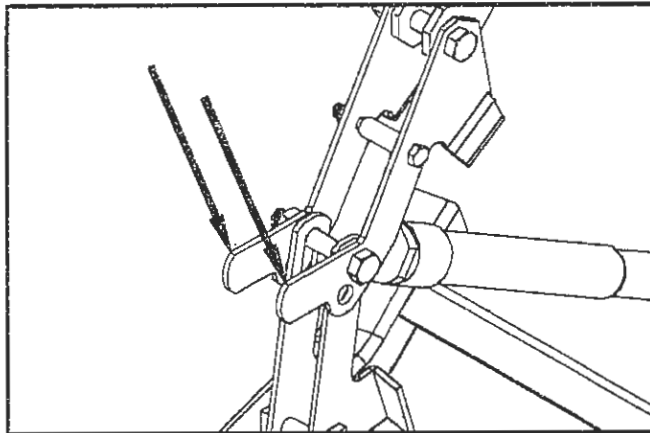

Retract Cylinder With Upper Lift Links DWG. NO. 4200

Swing the latch handle open until the latch sliders are fully removed from the attachment prongs.

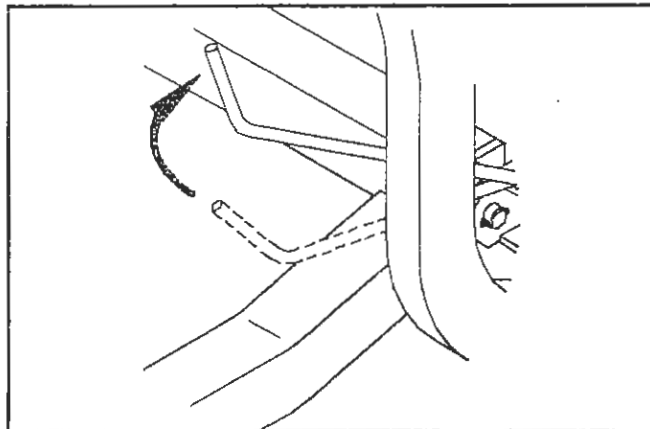

Swing Handle To Remove Sliders DWG. NO. 3856

Lower the parking stand to the ground by removing the tab lock pin from the stand index plate, then swinging the stand to the ground with the lever. Reinstall the pin in the index plate through the hole closest to the front of the lever to hold the stand in place.

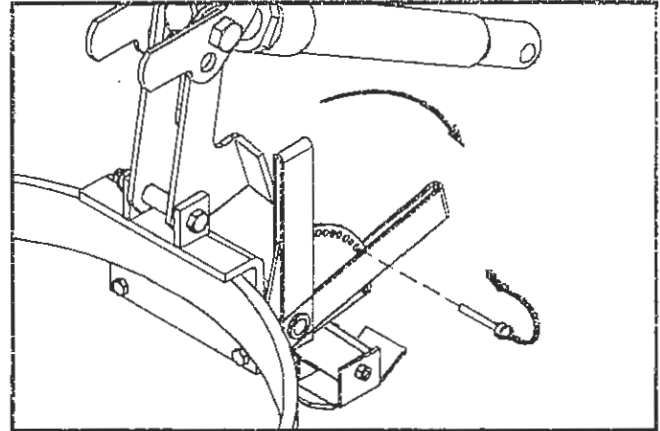

Lower and Pin Parking Stand DWG. NO. 4201

Disconnect the three electrical connectors by pulling them straight out from the receptacles. Do not twist the connectors, twisting will damage the connector pins or the wiring harness.

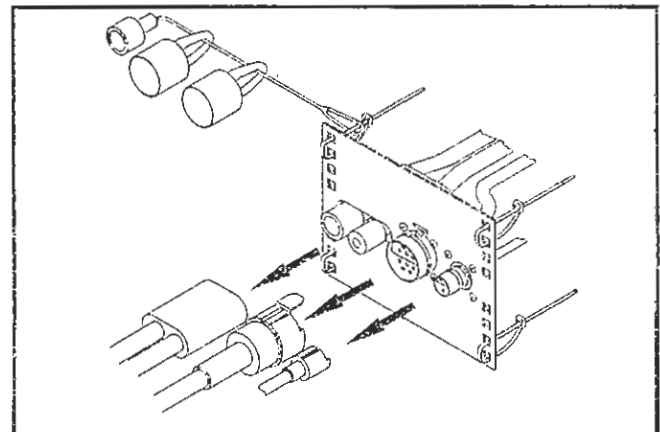

Disconnect Plugs DWG. NO. 4195

Back inside the truck, return control of the headlights to the truck and switch power off on the snowplow control box, then slowly back the truck out from the plow.

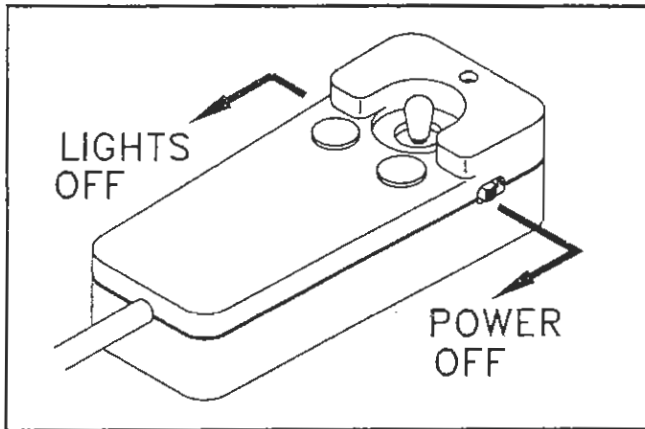

Turn Off Lights and Power

DWG. NO. 4164

If the snowplow won't be used for an extended period of time, the prong weldment can be removed from the truck by removing the hex bolts that fasten it to the truck mount frame.

TROUBLE SHOOTING

GENERAL

1. Check to see that the motor is wired correctly with tight connections, for the proper voltage.
2. Check reservoir oil level.
3. Check that wiring harness relay connections are wired correctly.
4. Check for external leakage at cylinders, hoses and power unit.

PROBLEM	POSSIBLE CAUSE	REMEDY
1. Plow does not attach to vehicle.	A. Receivers are tipped forward B. Prongs recoil out of receivers when attaching C. Park stand pinned too low	A. Fully collapse lift cylinder with upper lift links before removing plow from truck. B. Slowly drive into receivers and set parking brake. C. Lower receivers by adjusting park stand.
2. Pump motor does not run.	A. Defective solenoid B. Defective pump motor C. Weak or defective battery D. Bad electrical connections E. Defective joystick control box F. Blown fuse supplying power to control box	A. Replace solenoid. B. Replace pump motor. C. Charge or replace battery. D. Clean and tighten connections. E. Replace control box. F. Replace fuse.
3. Pump runs with joystick in neutral position.	A. Defective solenoid B. Defective joystick control box C. Wiring short	A. Replace solenoid. B. Replace control box. C. Locate and repair.
4. Plow will not lower.	A. Reversed wiring on valve block B. Defective joystick control box C. Defective lift return valve or coil	A. Correct wiring. B. Replace control box. C. Replace valve or coil.
5. Hydraulic cylinder does not function or functions slowly, motor runs.	A. Weak or defective truck battery B. Oil level low C. Hydraulic connection leak D. Solenoid valve not opening properly	A. Charge or replace battery. B. Add oil (do not overfill). C. Tighten or redo connection. D. Replace valve.
6. Plow does not remain raised with joystick in "neutral" position.	A. Leakage through pump check valve B. Leakage through solenoid lowering valve C. Internal leakage in cylinder D. Defective joystick control box.	A. Clean valve, or replace. B. Clean valve, or replace. C. Repack or replace cylinder. D. Replace control box.

PROBLEM	POSSIBLE CAUSE	REMEDY
7. Angling cylinders relieve too easily or too difficultly while plowing	A. Relief pressure set too low or too high	A. Have relief pressure adjusted by Hiniker snowplow dealer
8. Oil leaks from cylinder(s)	A. Loose packing B. Defective cylinder	A. Tighten packing 1/8 turn B. Repack or replace cylinder
9. Battery goes dead with power to the control box on and joystick in neutral position.	A. Short in wiring B. Defective joystick control box	A. Locate and repair B. Replace control box
10. Battery goes dead with power to the control box off.	A. Short in wiring	A. Locate and repair
11. Plow parking/turn lights are dim	A. Bad connection(s) B. Lights not properly grounded	A. Repair connection B. Properly ground
12. Plow does not clean-up snow from low areas	A. Controller not in float mode	A. Controller should be in the float mode
13. In extremely cold temperatures, the oil in the hydraulic system is thickened, causing slow functioning of the plow	A. Cold temperatures	A. As the system warms, the oil will thin out and function normally. B. Select a recommended oil from the chart in the "Maintenance section for plowing in extremely cold temperatures.
14. Pump chatters when raising plow	A. Hydraulic oil low	A. Add hydraulic oil until chattering stops. Do not overfill.
15. Oil running out of cap on hydraulic reservoir	A. Plowing on steeply inclined terrain B. Too much oil	A. Avoid excessive inclines or change direction of plowing B. Remove excess oil
16. Vehicle overheats with the plow on	A. Vehicle coolant level low B. Ice and snow buildup in grill C. Insufficient airflow to engine compartment	A. Add coolant B. Remove ice and snow C. Transport plow at lower speeds
17. Plow lights do not operate with plow attached	A. Light switch on joystick control box in "truck" position B. Defective relay C. Faulty light switch on joystick control box D. Blown fuse in harness or vehicle	A. Move switch to "plow" position B. Replace relay C. Replace joystick control box D. Replace fuse
18. Truck headlights do not operate properly with plow removed	A. Light switch on joystick control box in "plow" position B. Defective relay	A. Move switch to "truck" position B. Replace relay

MAINTENANCE

Dependable snowplow operation is the result of following good maintenance procedures. Inspect your plow frequently to ensure that all parts are working smoothly, and develop a schedule for maintenance at required intervals.

GENERAL

Wash salt and dirt off the plow before storage. Touch-up any chips or scratches in the paint and apply a light coating of grease to extended cylinder rods to prevent corrosion.

HYDRAULIC SYSTEM

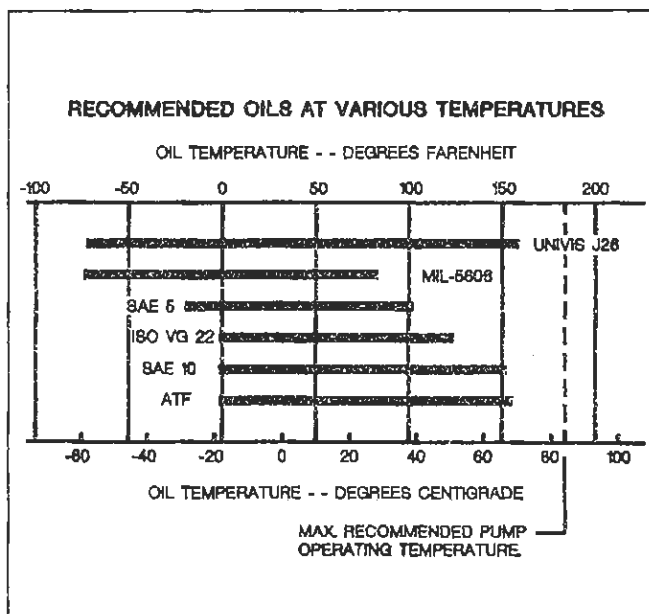

DWG. NO. 3066

The majority of snowplow operational problems are caused by bad oil in the hydraulic system. Hydraulic oil should be changed every year for best performance. Select a high quality oil that is appropriate for the temperatures in which you will be plowing snow.

To change hydraulic oil, first pin the upper and lower moldboard halves together through holes in the ribs to prevent the upper half from falling forward when the hydraulic lines are removed. Disconnect the electrical wiring harnesses from the power unit and uncouple five hydraulic lines. Unbolt the power unit from the plow, and remove it to a clean working area that can capture any spilled oil.

Carefully unbolt the oil reservoir from the power unit and discard old oil. Purge old oil from the angling cylinders by forcing rods to retract.

Clean the suction filter at the pump inlet and wipe any metal shavings off the magnet on the pump.

Assemble the reservoir onto the power unit and fasten the power unit onto the snowplow before adding new hydraulic oil.

Pour hydraulic oil into the power unit reservoir until the reservoir is half full. Angle the plow full left or right to fill the angling cylinder with oil, then add more oil until the oil reaches the fill line - about 1 1/4 inches from the top. Do not overfill the oil reservoir.

Reattach hydraulic hoses and electrical wires at the correct locations on the power unit and un-pin the upper and lower moldboard halves. Cycle the plow left and right, up and down, and work the fold mechanism to purge any air trapped in the system.

Check the oil level with the plow on the ground and the blade uncurled. Add oil to the fill line, if necessary, but do not overfill the reservoir.

MECHANICAL COMPONENTS

Prior to the operation of a new snowplow, or one which has been stored, inspect all hardware and verify proper torque on all bolts and nuts in accordance with the recommended torque specifications.

GRADE 5 TYPE B & F LOCKNUT TORQUES

Size	Ft-lbs.	N-m
5/16"	13-18	17-25
3/8"	23-33	31-44
1/2"	58-82	79-112
5/8"	117-165	158-223

GRADE 5 BOLTS TORQUES*

Size	Ft-lbs.	N-m
1/4"	8-12	11-16
3/8"	29-41	39-56
1/2"	73-103	99-140
5/8"	146-206	198-279

* applications without locknuts

Loose bolts can cause hole elongation and part failure resulting in dangerous operating conditions and equipment breakdown.

Check all hardware periodically during operation and keep tightened to specified torques. Replace worn bolts and locknuts with grade 5 bolts and equivalent type B or type F locknuts. Type B locknuts are plain hex; type F locknuts are flanged hex.

Once a year before using the plow, check that the moldboard will trip freely about its three hinge pins. With the snowplow mounted on the truck, the cutting edge on the ground, and the upper and lower moldboard sections pinned together, remove the compression springs from the back of the moldboard by loosening the 3/4" locknuts behind the springs and pull the top of the moldboard fully forward. If the moldboard doesn't pivot freely, remove the three hinge pins one at a time by driving a spring pin out from one end of the hinge pin, and coat each pin with a commercially available anti-seize lubricant. Damage to the snowplow or the truck may result if the moldboard hits an obstruction during use and doesn't trip.

Reassemble the compression springs, washers and locknuts onto the threaded pullrods, and tighten the locknuts until the springs measure 13 inches long.

The 5/16" hex bolts in the latch sliders are factory retained with anaerobic threadlock. If removal or replacement of these bolts is necessary, purchase new bolts with threadlocker from your Hiniker dealer, or apply a commercially available threadlock, i.e., Locktite 242 (blue) or Perma-Lok HM118 (red), to standard 5/16-18 x 3/4" grade 5 hex bolts before reassembly.

The black vinyl caps on the C-Plow blade markers are factory retained with Locktite 409 Superbond. If replacement is required, secure new caps with an equivalent adhesive.

ELECTRICAL MAINTENANCE

Periodically check all electrical connections for proper fit and remove any contamination that may be present.

To prevent contamination always place dust caps on connectors when not in use. This is particularly important when the plow is being stored. The use of dielectric grease is recommended to reduce corrosion of the contacts and to make connection and disconnecting of connectors easier.

Before each season check vehicle battery and electrical system for proper operation. A weak battery, dirty terminals, or faulty charging system may cause improper operation and possible failure of the joystick controller.

FLOW ASSEMBLY

GENERAL INFORMATION



WARNING: To prevent personal injury or death, be certain to keep clear of any parts that may drop when removing bundling straps, wires or brackets. Support heavy sections with hoist or blocks before removing wires or straps.

In the following instructions, left and right machine references are defined as being viewed from the cab of the truck

Be certain that hydraulic hoses and electrical wires are safely routed and allow full motion of moving parts. Secure loose wires with plastic tie straps.

Some components are fastened at incorrect locations for shipping purposes.

All hardware should be tightened only enough to insure safety during assembly. Torque hardware to specified values, as shown in the following chart, only after assembly has been completed.

GRADE 5 TYPE B & F LOCKNUT TORQUES

Size	Ft-lbs	N-m
5/16"	13-18	17-25
3/8"	23-33	21-44
1/2"	58-82	79-112
5/8"	117-165	158-223

GRADE 5 BOLT TORQUES*

Size	Ft-lbs.	N-m
1/4"	8-12	11-16
3/8"	27-41	39-56
1/2"	73-103	99-140
5/8"	146-206	198-279

* applications without locknuts

Replace worn bolts and locknuts with grade 5 bolts and equivalent type B and type F locknuts.

Type B locknuts are plain hex; type F locknuts are flanged hex.

FLOW ASSEMBLY

1. Place moldboard face down on cardboard or other padding that will prevent scratches in the paint.

Remove the three hinge pins from the back of the moldboard by driving out one spring pin, and save for reinstallation.

Remove the hydraulic cylinder assembly from the back of the moldboard by snipping the plastic band and unpinning the cylinder rod. Also, remove the 3/4 inch x 6 inch clevis pin and spacer bushing from the moldboard plates, and remove the 3/4 inch x 4 1/2 inch clevis pin from the short pair of links on the cylinder assembly. Loosen the plugs in the cylinder ports and fully extend the cylinder rod.

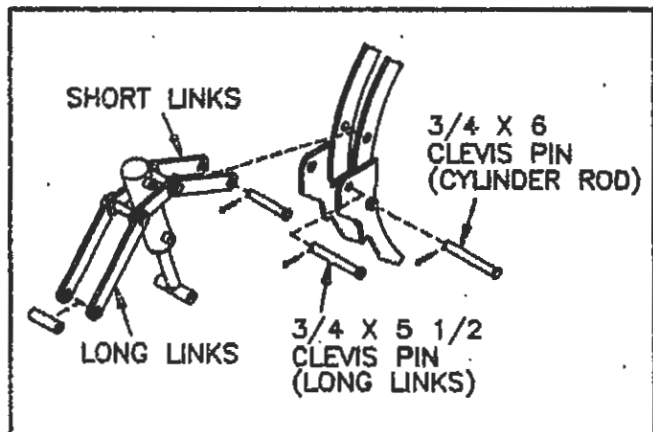

DWG. NO. 3914

Pin the short pair of links outside the center ribs with the 3/4 inch x 4 1/2 inch clevis pin and cotter pin.

Pin the cylinder rod between the reinforced holes in the moldboard plates with the 3/4 inch x 6 inch clevis pin and cotter pin.

Pin the long pair of links and the spacer bushing between the upper holes in the moldboard plates with the 3/4 inch x 5 1/2 inch clevis pin and cotter pin.

- Remove the two 3/8 inch x 5 inch hex bolts from the upper and lower pairs of ribs on the back of the moldboard.

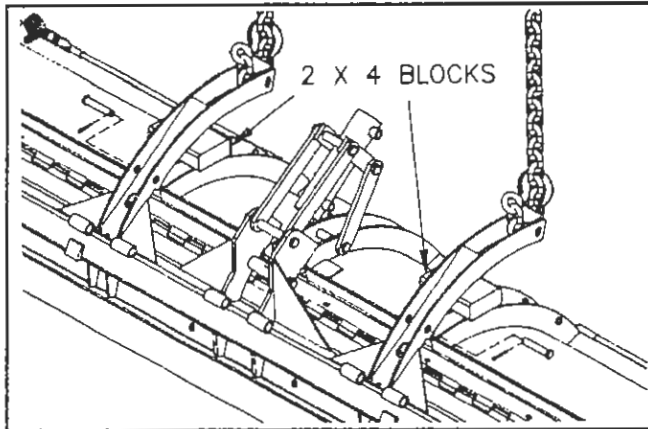

DWG. NO. 3916

Lift up on the inner sets of ribs with hoist chains until the two 5/8 inch x 3 inch clevis pins can be easily removed. Place 2 x 4 wooden blocks between the two sets of ribs to hold the moldboard at this position before lowering the chains.

Open the frame crate and set aside the power unit box, headlamp boxes and parts box for later assembly.

Carefully lift the frame assembly by wrapping hoist straps or padded chains around both ends of the 2 1/2" square tube at the rear of the frame.

Attach the frame assembly to the moldboard by lining up the three bushings on the frame with the three sets of bushings on the moldboard.

Apply a commercially available anti-seize lubricant (not supplied) to the hinge pins to prevent future corrosion, and reinstall the hinge pins through the bushings. Secure the hinge pins with spring pins.

Remove 3/4" locknuts from the back of each compression spring. Align each pullrod bushing with the holes in the moldboard ribs and reinstall 5/8 inch clevis pins and cotter pins.

Assemble 3/4" locknuts back onto pullrods and tighten until compression springs measure 13" long. Do not overtighten springs.

Remove the wooden blocks and reinstall the two 3/8 inch x 5 inch hex bolts through slots in the upper and lower pairs of ribs.

- Gently tip the plow assembly to its working position with a hoist or forklift. Pin the parking stand to hold the square tubes of the push frame parallel to the ground.

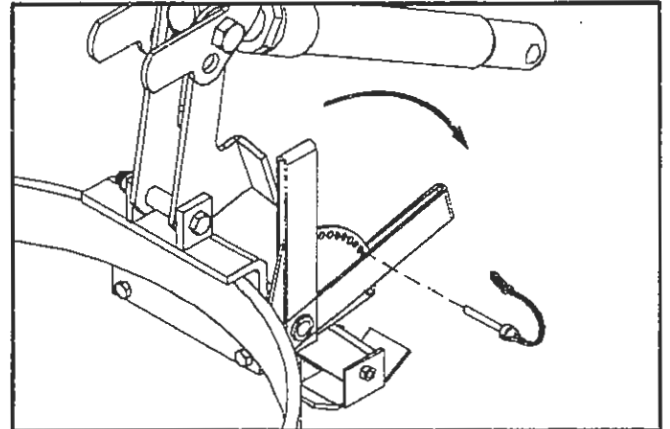

DWG. NO. 4201

Swing the lift frame up to its approximate working position and hold with a hoist or forklift for assembly of the lift mechanism.

The bottom surface inside the two prong receiver channels should measure about 10 inches above the ground in the working position.

- Locate a 90° O-ring/flare adapter in the hardware bag from the parts box. Turn the O-ring end into the port of the lift cylinder so that the flare end is toward the rod end of the cylinder when tightened.

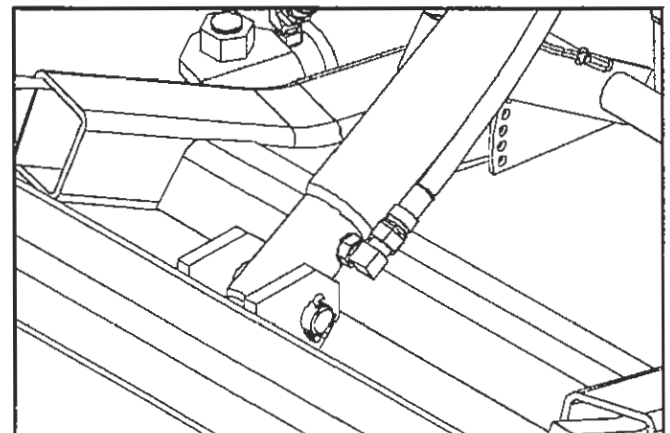

DWG. NO. 4202

Pin the base of the cylinder between the center lugs of the lift frame with the 3/4" x 3" clevis pin provided. The hydraulic fitting should be on the right side of the cylinder.

16 Plow Assembly

Remove four lift links from the parts box. From the hardware bag, remove two 3/4" x 4 1/4" hex bolts, two 3/4" lock nuts and two 3/4" I.D. shim washers. Also remove one 1/2" x 3 1/4" hex bolt, one 1/2" lock nut and the upper link spacer bushing.

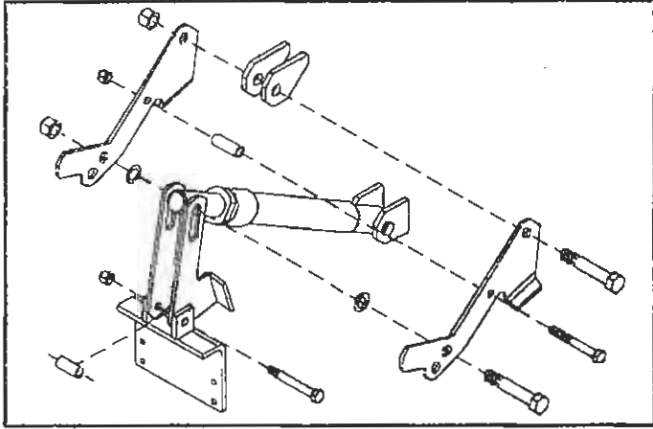

DWG. NO. 4203

Identify the RH and LH upper and lower links by referring to Drawing 4203. Links should be assembled with stop surfaces away from the lift cylinder.

Disassemble the 1/2" x 4" hex bolt and spacer from between the tabs on the push frame. Bolt the two lower links inside the tabs, with the spacer between the links.

Assemble the two upper lift links outside the lugs on the lift frame with a 3/4" x 4 1/4" hex bolt and lock nut. Bolt the upper link spacer bushing between the two upper links with the 1/2" x 3 1/4" hex bolt and lock nut from the hardware bag.

Complete the lift mechanism assembly by bolting the lift cylinder rod, lower links and two shim washers between the upper links.

Insert the 3/4" x 4 1/4" hex bolt through the upper pair of the two bottom holes in the upper lift links for most vehicles, then secure the assembly with the 3/4" lock nut. Bolting through the lower pair of holes will increase downward plow travel for taller trucks, but reduce lift height.

5. Before assembling the power unit on the lift frame, scrape a small amount of paint from the two mount holes in the lift frame to provide a good electrical ground for the turn signals and parking lights.

Mount the power unit on the lift frame with two 3/8" x 3/4" hex bolts and two 3/8" lockwashers. The plastic reservoir of the power unit should be to the left side of the plow.

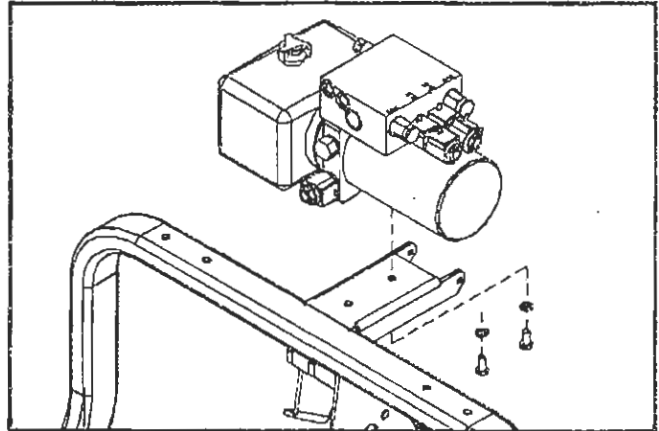

DWG. NO. 4204

Locate the five straight O-ring/flare hydraulic fittings in the hardware bag. Install the O-ring ends of the five straight fittings into the five ports in the power unit.

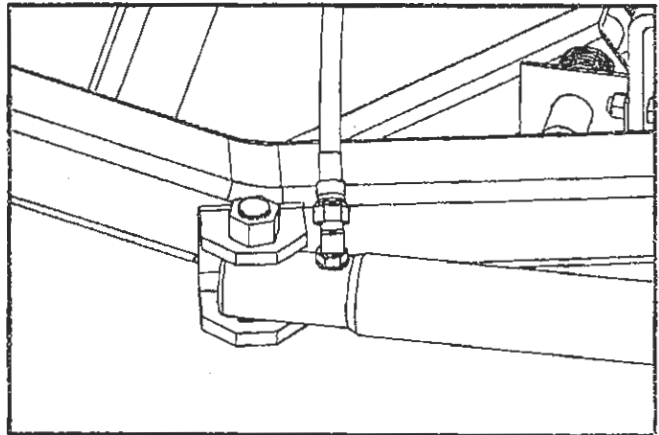
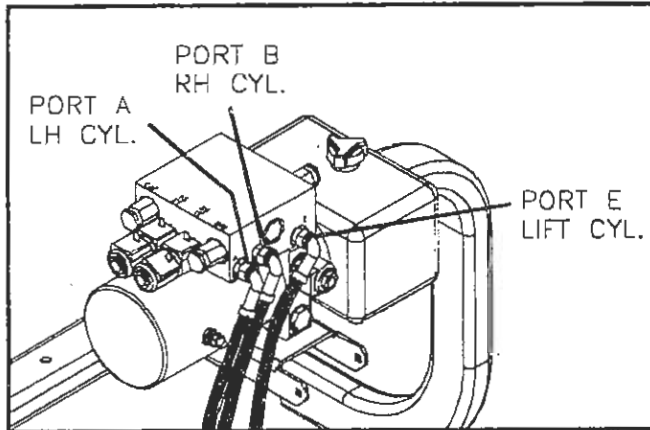

PHOTO NO. 4205

Locate two 45° O-ring/flare hydraulic fittings in the hardware bag, and install them into the ports of the angling cylinders so that the flare ends are nearly parallel to the mount lugs of the push frame.

Identify five hydraulic hoses in the parts box. The two longest hoses measure 66 inches long, one hose is 54 inches long and the two shortest hoses are 33 inches long.

The 54 inch long hose connects port A on the power unit to the LH angling cylinder. Connect the 90° hose end to port A, then route the hose along the cross brace at the rear of the push frame before connecting the straight end to the cylinder. Strap the hose to the brace with plastic tie straps.



DWG. NO. 4206

Connect one of the 33 inch long hoses between port B on the power unit and the RH angling cylinder.

Connect the last 33 inch long hose between port E on the power unit and lift cylinder.

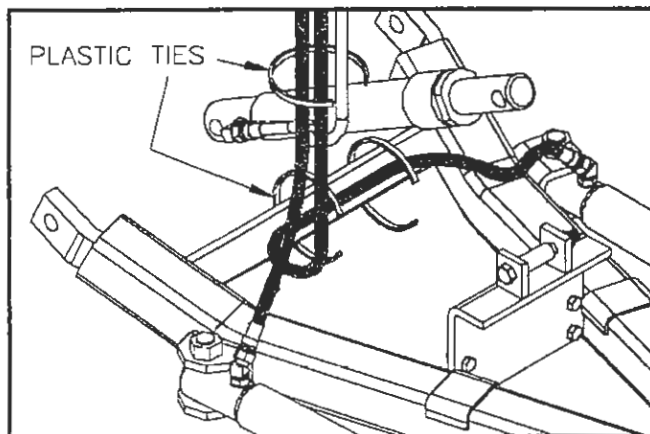

DWG. NO. 4207

Strap three hoses from the angling and lift cylinders together with a plastic tie, as shown in the drawing.

The two 66 inch long hoses will connect ports C and D on the back of the power unit to the roll over cylinder.

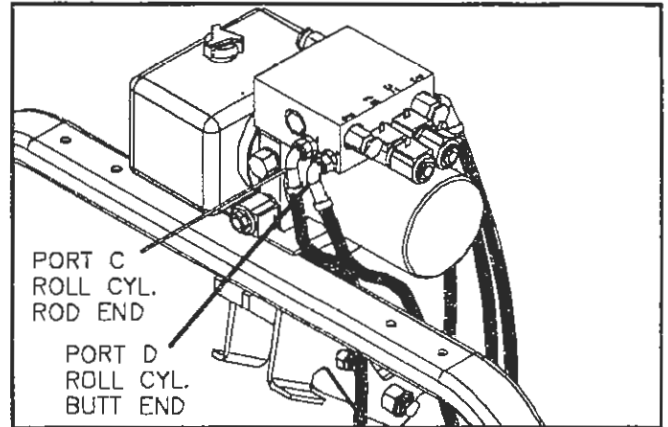

DWG. NO. 4208

Route both hoses ahead of the lift frame tube and through the hose loop on the push frame so that the 90° hose ends are toward the power unit and the straight ends are toward the cylinder.

Assemble one of the hoses between port C on the power unit and the rod end of the roll over cylinder. Connect the last hose between port D and the butt end of the roll over cylinder.

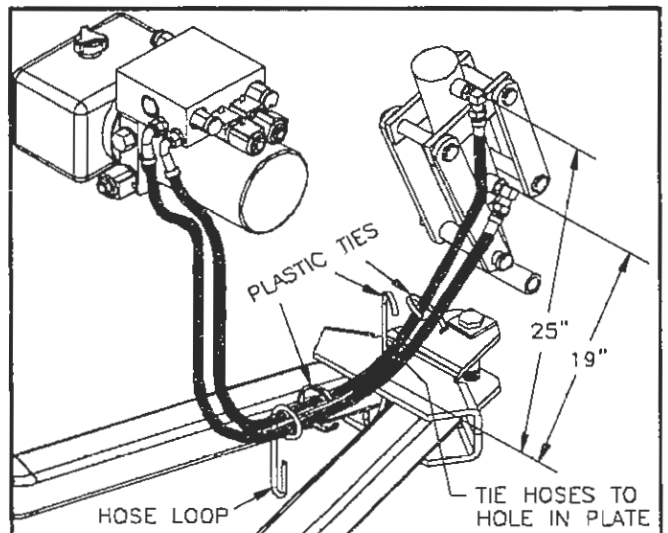

DWG. NO. 4209

Band both hoses of the upper plate of the push frame at the approximate dimensions shown in the drawing. Also band the hoses together just ahead of the first tie and just ahead of the hose loop.

6. Before assembling the headlamp brackets on the lift frame tube, scrape a small amount of paint from the three holes in each bracket and from the four holes in the frame tube to provide a good electrical ground for the turn signals and parking lights.

18 Plow Assembly

Mount the headlamp brackets to the lift frame tube with four 3/8 inch x 2 Inch carriage bolts and flanged lock nuts from the hardware bag in the parts box.

Remove the LH and RH headlamps from their boxes and mount on the brackets with hardware from the head lamp boxes.

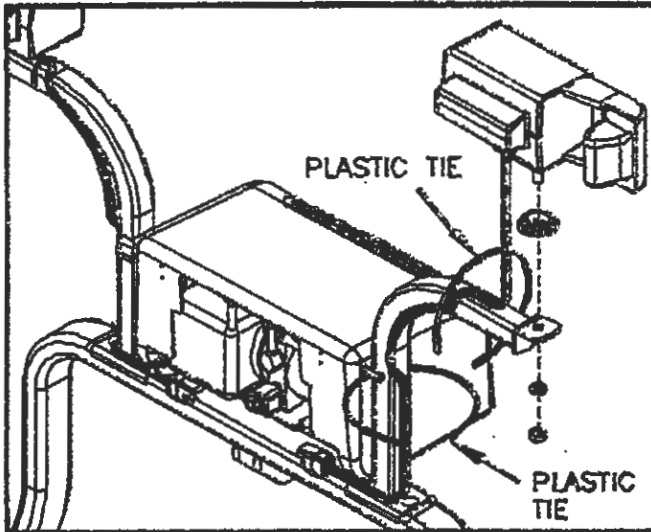

DWG. NO. 4172

7. Identify the plow power cable assembly and the plow wiring harness in the parts box.

The power cable for the snowplow has two cables with ring terminals on one end and a two pin connector on the other, and measures about 38 inches long.

The plow wiring harness has a ten pin connector and a 3 pin connector on one end and the other end has connectors labeled "DRIVER SIDE" and "PSNGR SIDE" for the headlamps, and six loose wires with spade receptacles and one wire with a ring terminal.

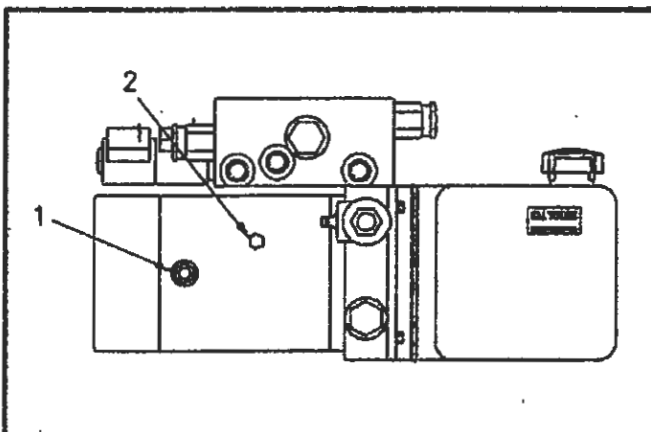

DWG. NO. 3921A

Attach the ring terminal of the solid red (or red striped) wire of the power cable assembly to the terminal on the power unit at location 1. Fasten the ring terminal of the solid black wire of the power cable assembly and the black wire with the ring terminal on the plow harness under the screw on the motor at location 2.

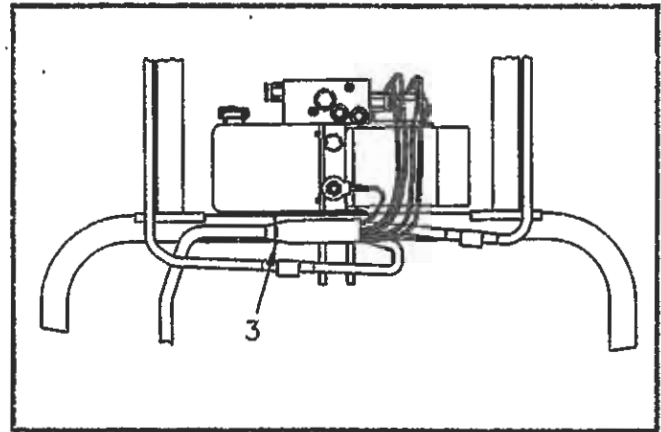

DWG. NO. 4218

Band the plow wiring harness to the frame tube with a plastic tie strap, as indicated in the photo at location 3. Refer to the photo and drawing for routing wires to the power unit and headlamps.

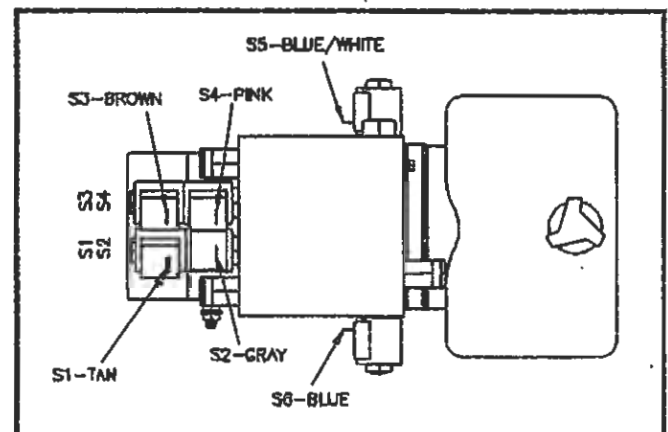

DWG. NO. 3920A

Connect the Tan wire of the plow wiring harness to the spade terminal on solenoid S1.

Connect the Gray wire to solenoid S2.

Connect the Brown wire to solenoid S3.

Connect the Pink wire to solenoid S4.

Connect the Blue with White Stripe wire to solenoid S5.

Connect the Blue wire to solenoid S6.

Connect the RH headlamp to the harness end labeled "PSNGR SIDE" and the LH headlamp to the end labeled "DRIVER SIDE".

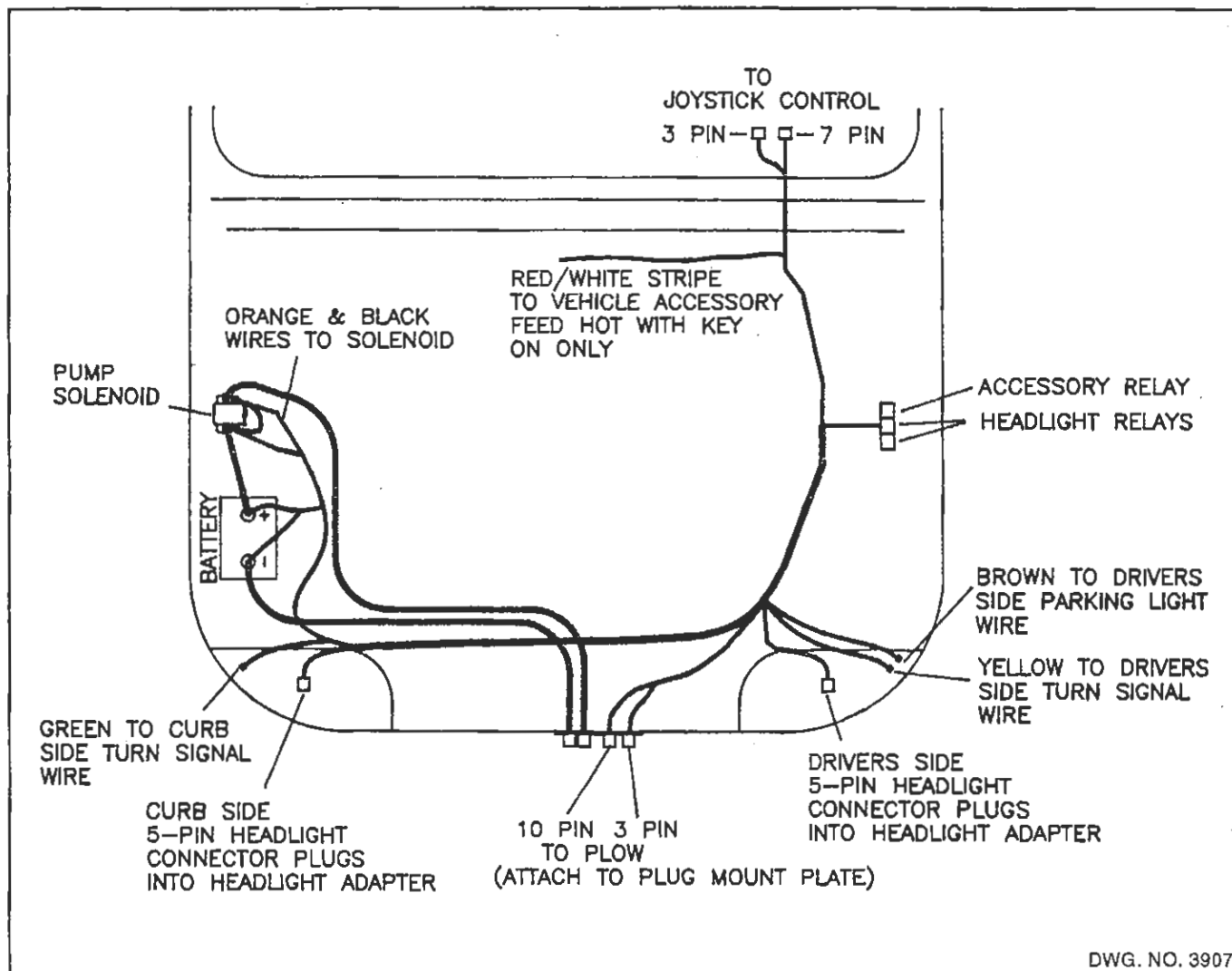

WARNING: Disconnect truck battery before beginning electrical installation to avoid shock hazard.

The pump solenoid, underhood wiring harness, power cable and joystick control box are located in the parts box shipped with the snowplow frame.

NOTE: Fill electrical connectors with dielectric grease, and lightly coat ring and spade terminals before installation to prevent corrosion.

8. To begin underhood wiring installation, lay the harness in its approximate position for final assembly. Position the 7-pin and 3-pin circular connectors near the driver's side firewall, the 10-pin and 3-pin connectors just left of center near the grill, the relays near the driver's side inner fender and the 5-pin headlight connectors at the respective headlights.

9. Determine the location of the vehicle battery. If the battery is located on the right (passenger) side, or if there are two batteries configured as a 12 volt system, then proceed to step 10. If the battery is located on the left side of the vehicle then the wiring harness will need to be modified, as follows.

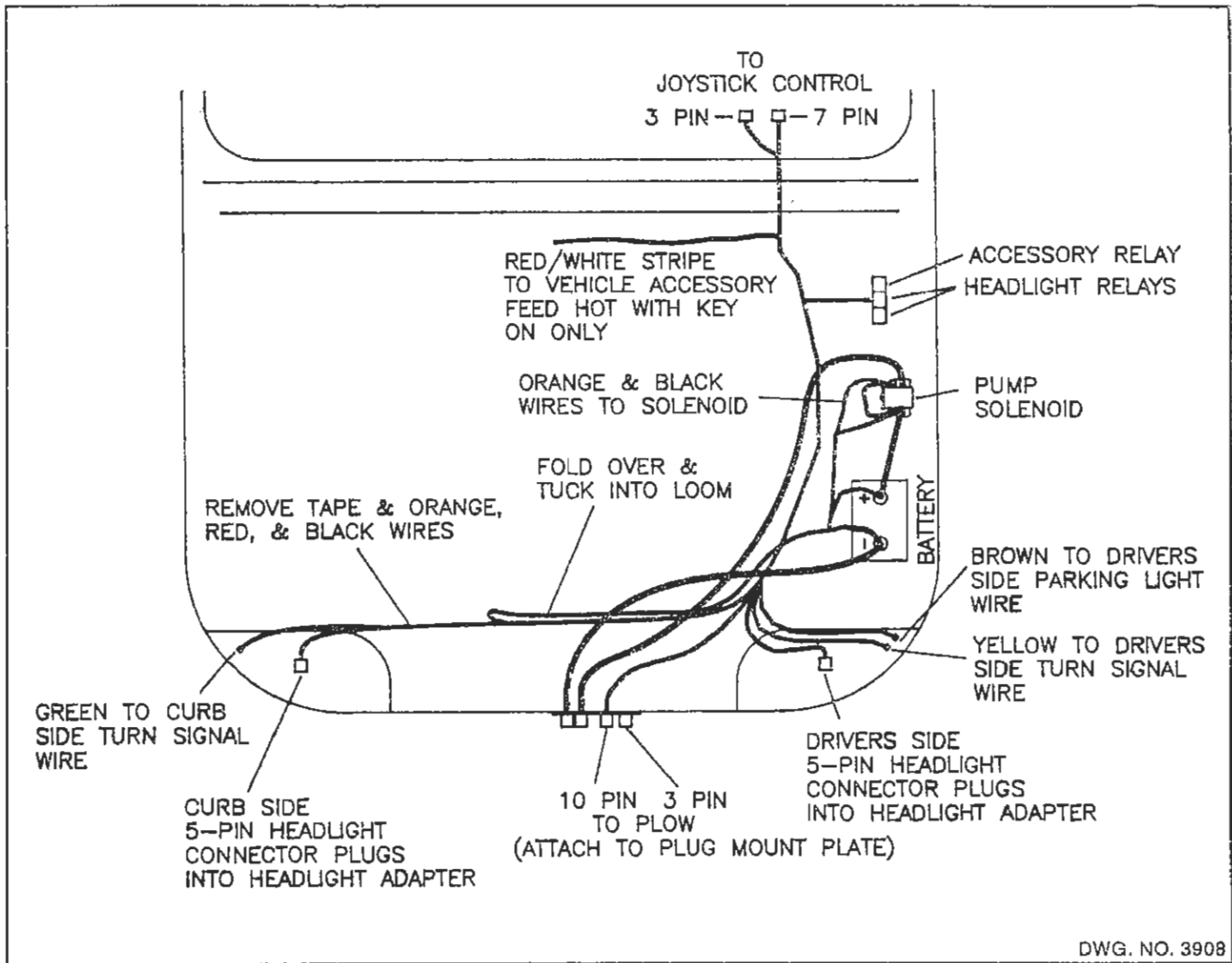

DWG. NO. 3908

Refer to drawing 3908.

Remove the tape from the Black corrugated loom at the points shown. Locate an Orange, Red, and two Black wires. These wires connect to the battery and pump solenoid located next to the battery. Remove the four wires from approximately 33 inches of the loom, making sure the Red and Black wires are long enough to connect to the battery. Tuck these wires back into the loom as shown in the drawing and retape the loom.

10. If there is no access hole in the drivers side firewall then drill a 1-1/8 inch diameter hole. Route the 7-pin and 3-pin circular connectors through the firewall into the cab compartment and install the 4-inch grommet in the hole, if required.

11. Select an area near the drivers side fender for the relays. Drill three 1/8 diameter holes and secure the relays with #8 x 1/2 inch self-tapping screws from the hardware bag in the parts box.
12. Splice the red with white stripe wire to the vehicle's switched 12 volt auxiliary electrical circuit. This will prevent operation of the plow without the vehicle key being on. This wire controls the accessory relay that powers the control joystick and solenoids.
13. Connect the joystick control box to the 7-pin and 3-pin connectors inside the truck cab. Secure the box at a safe location in the cab with the strip of hook and loop fastener.



CAUTION: Ensure that the relays will clear any hood lift/spring mechanisms before installation.

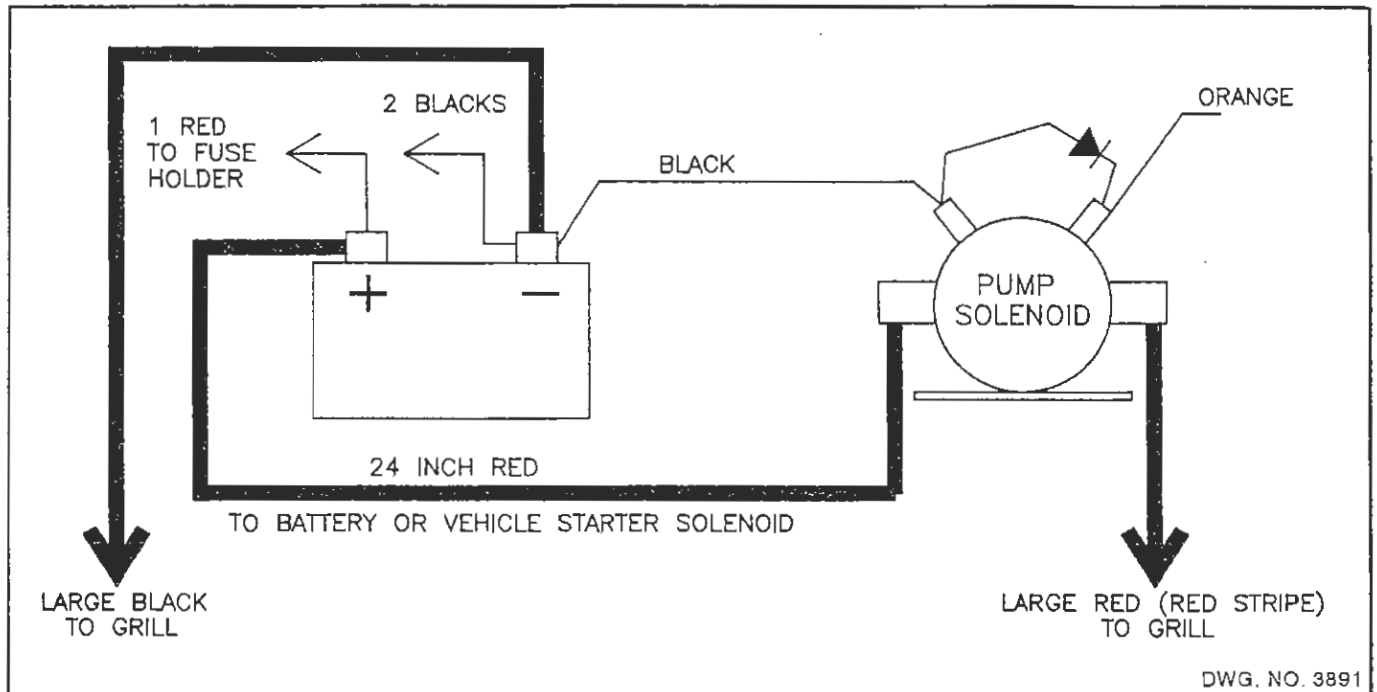

WARNING: Ensure that the pump solenoid and associated wiring will clear any hood lift/spring mechanisms before installation.

14. Select an area within 16 inches of the vehicle battery for the pump solenoid. Drill two 3/16 diameter holes and fasten the solenoid with two 1/4 inch x 1/2 long self tapping screws from the hardware bag in the parts box. Connect the Black wire to one of the small posts on the solenoid, connect the Orange wire to the remaining small post, polarity if not important.
15. Safely route the 10-pin and 3-pin circular connectors through the grill of the vehicle to a location that will be easily accessible with the plow attached.
16. Refer to drawing 3891. Install the underhood power cable by first connecting the ring terminal from the solid Black cable and the two Black wires from the harness to the minus(-) post of the vehicle's battery. Connect the ring terminal from the solid Red (or Red striped) cable to the pump solenoid terminal, route the power cable to the grill near the 10-pin connector.

Install the 24 inch Red power cable between the pump solenoid and the vehicle's starter solenoid positive terminal. If the vehicle's starter solenoid is not accessible, connect the Red (or Red striped) cable to the plus (+) terminal of the battery. Connect the Red fused wire to the positive terminal of the battery.

17. Remove the plug mount plate, plastic clamp and mounting hardware from the hardware bag in the parts box.

Refer to drawing 4193.

Fasten the power cable connector to the clamp by inserting the #6 x 1 inch machine screw through the small hole in the connector, then through the center hole of the clamp. Secure the screw with a #6 lock nut.

Fasten the clamp to the mount plate with the two #10 x 1-1/2 inch machine screws and #10 lock nuts supplied.

Mount the 10-pin circular connector to the mount plate with four #6 x 1/2 inch screws and lock nuts such that the tab on the connector will be up, as shown.

Mount the 3-pin circular connector to the mount plate with four #6 x 1/2 inch screws and lock nuts such that the tab on the connector will be up, as shown.

Assemble the mount plate and connector covers to the vehicle grill with plastic ties.

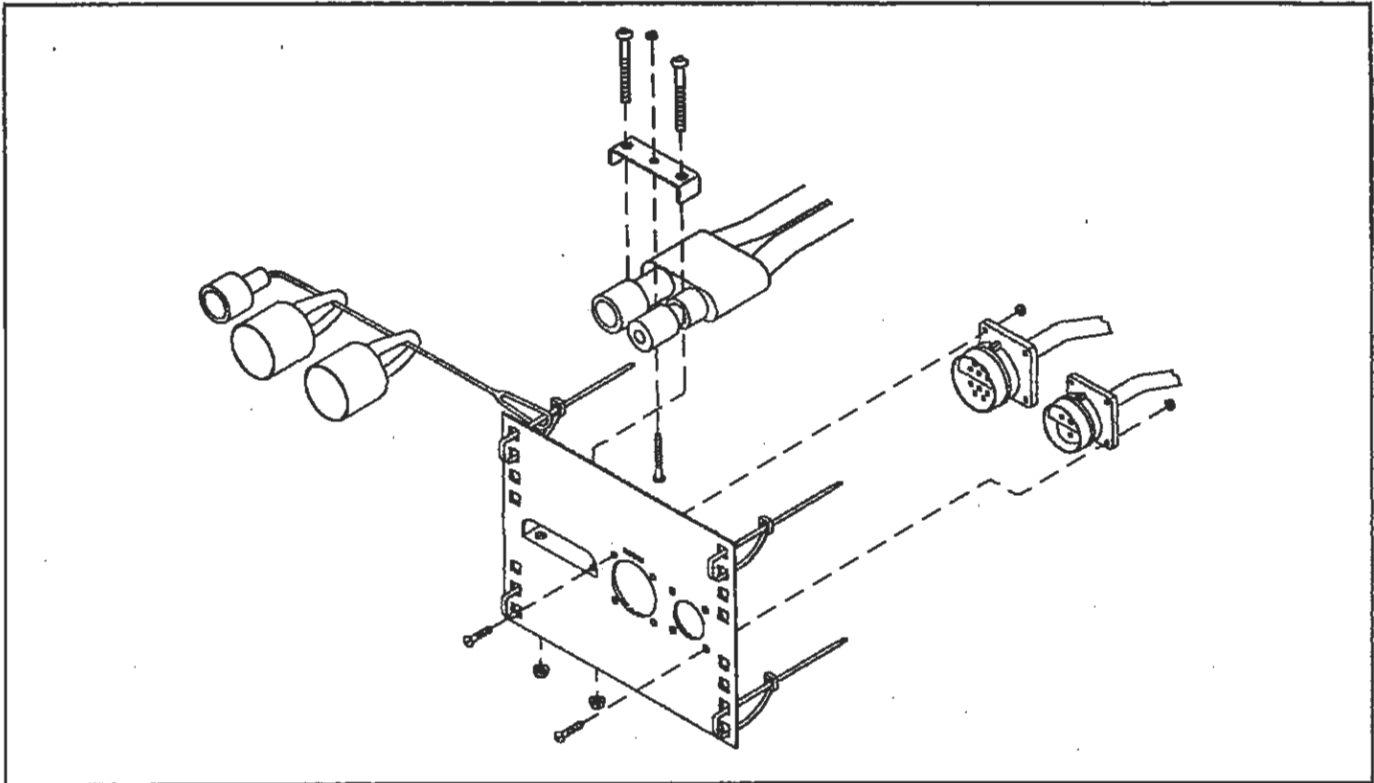

DWG. NO. 4193

18. Locate three blue connector splices in the hardware bag in the plow's parts box.

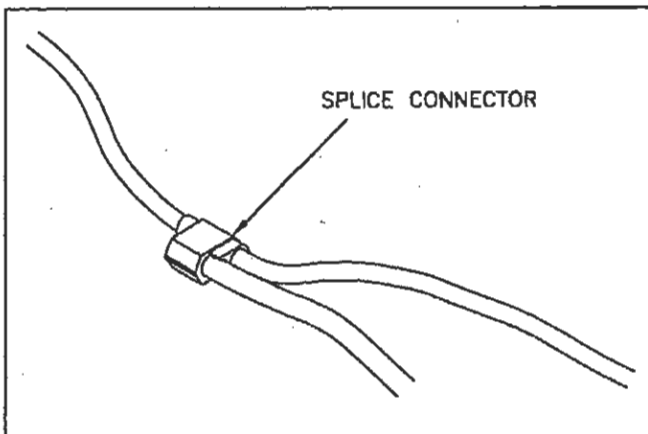

DWG. NO. 4165

Using a blue splice, crimp the single brown wire from the underhood harness into the vehicle's drivers side parking light wire.

Using a blue splice, crimp the single yellow wire from the underhood harness into the vehicle's drivers side turn signal wire.

Using a blue splice, crimp the single green wire from the underhood harness into the vehicle's curbside turn signal wire.

19. Select the proper headlight adapter for your vehicle, specific instructions are included with each kit.

The headlight adapter kit consists of two identical adapters. Install the adapters according to the instructions included with the kit and connect to the 5-pin connectors of the underhood wiring harness.

20. Secure all cables away from hot or moving components with cable ties.

This completes the Electrical Installation.

21. At this point, the mount kit should be assembled onto the truck.

Prongs from the truck mount kit should be at a height that will slightly lift the plow frame when attaching the plow. Prong receivers on the plow frame should be parallel to the ground when attaching the plow. Apply powdered graphite on the truck prongs to help the plow to slide on and off more easily.

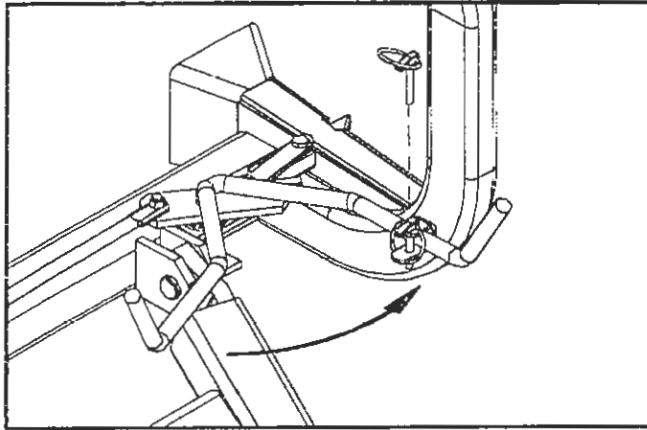

DWG. NO. 4199

Attach the plow onto the truck by driving the truck prongs into the receivers on the plow frame. Pull the latch handle into the frame clevis to move sliders through the notches in the prongs and receivers. Pin the handle in the clevis with its klik pin. Raise the parking stand to its highest position and repin. Connect the three electrical cables from the plow to their corresponding receptacles on the truck.

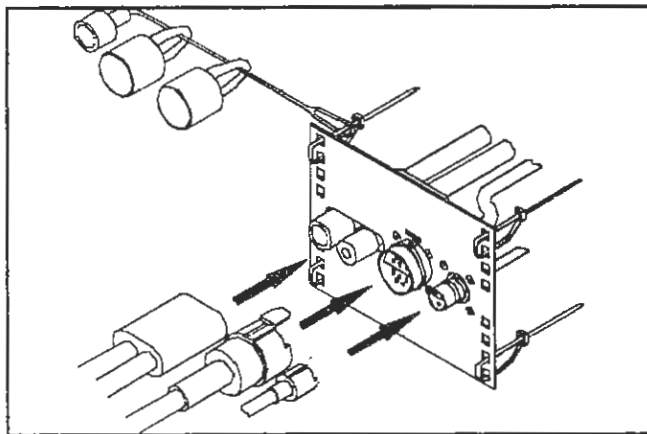

Alignment Tab and Slot

DWG. NO. 4192

Select an appropriate hydraulic oil from the following chart.

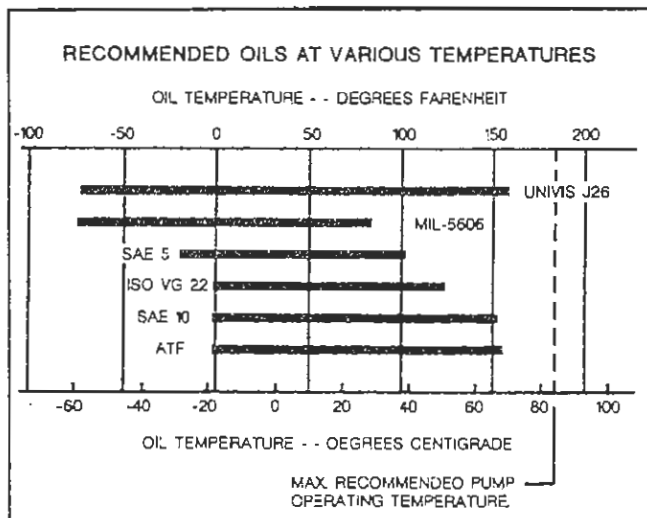

DWG. NO. 3066

Pour hydraulic oil into the power unit oil reservoir until the oil level reaches the fill line - about 1 1/4 inches from the top.

Remove the two 3/8 inch x 5 inch hex bolts from between the upper and lower pairs of ribs on the back of the moldboard.

Raise and lower the plow, cycle the wings, and work the roll over function of the plow to purge any air trapped in the system.

Check the oil level with the plow on the ground and the blade uncurled. Add oil to the fill line, if necessary, but do not overfill the reservoir.

NOTE: New hydraulic cylinders will leak a small amount of oil until packings become saturated and produce a good seal. If leakage is excessive, or if leaking continues after initial cycling, tighten the cylinder packing nut in 1/8-turn increments until leaking stops.

- Fasten the power unit cover onto the lift frame bracket with two 1/4" x 3/4" carriage bolts, flat washers and locknuts from the hardware bag in the parts box. Tighten the locknuts so that the assembly is secure, yet the cover hinges freely.

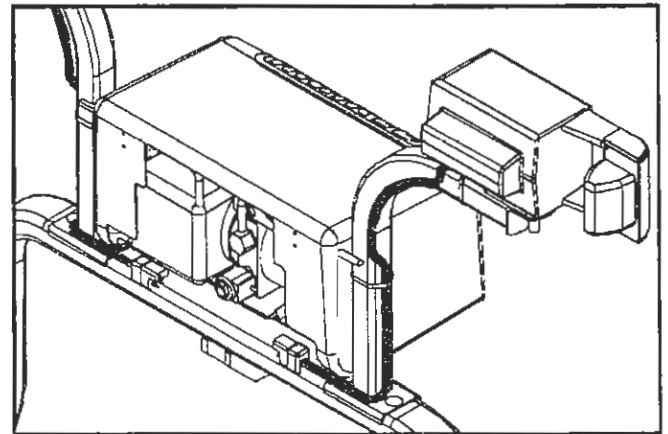

DWG. NO. 4198

Snip the plastic tie strap inside the cover assembly to release the two cover latch handles. When the cover is closed, rods from the latch handles should extend behind the light brackets to hold the cover in place.

- Loosen the locknuts fastening the marker springs to the moldboard. Turn the markers to point up, then retighten the hardware.

SPECIFICATIONS

Blade Width	8'	
Plow Width at 31°	6'10"	
Blade Height	28 1/2"	
Lower Cutting Edge	3/8"x 6" 1084 Steel w/Standard Highway Punch	
Upper Cutting Edge	1/4"x 4" 1044 Steel w/Standard Highway Punch	
Weight	C-Plow	800 lbs. (Does Not Include Weight of Mount Kit)
	Wing-Kit	31 lbs.
Hydraulic Oil Capacity	2-1/2 qts.	
Sealed Beam Headlight	HP6545 12 VDC 4.00" x 6.50" (100mm x 165mm) Rectangular Hi/Low (65w/45w)	
Turn Signal/Parking Bulb	One # 1157 Heavy Duty Double Contact 32/3 C.P.	
Starter Solenoid	12 VDC Solenoid Start Switch	
Wiring Harness Fuse	10 AMP	

CAB CONTROL

UNDERHOOD HARNESS

EXTERNAL HARNESS

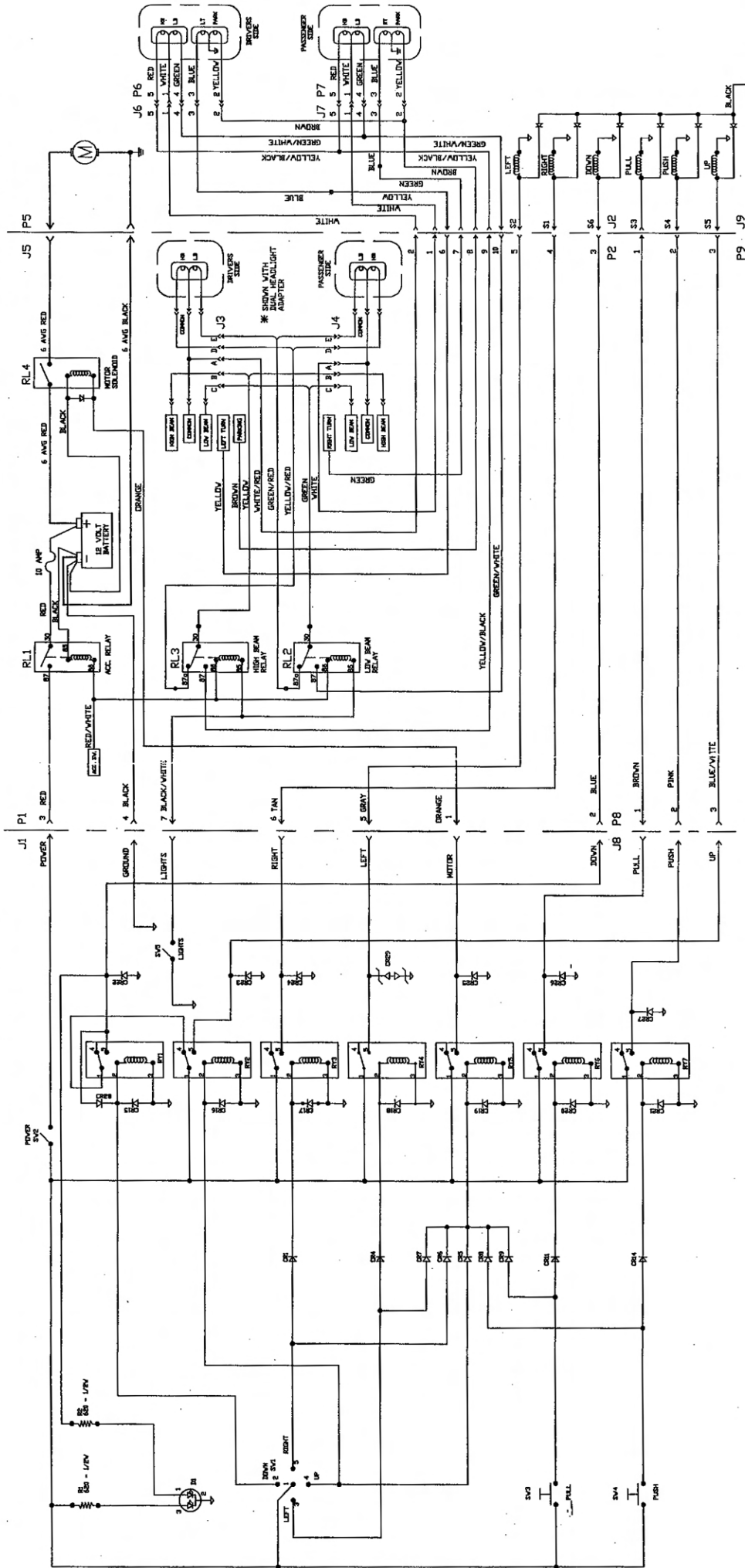

DWG NO: 4219
DATE: 5-15-02
C-PLDV 2002

C-PLOW POWER UNIT

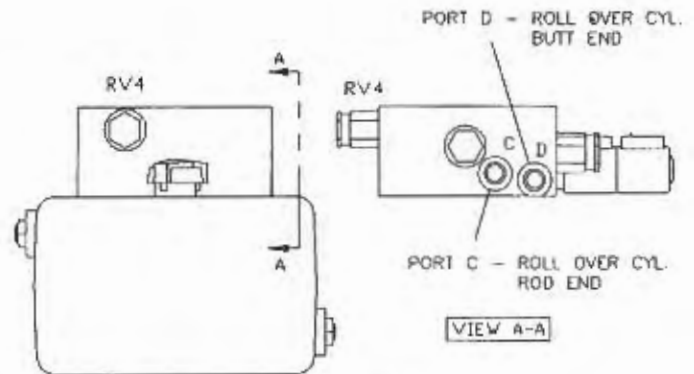
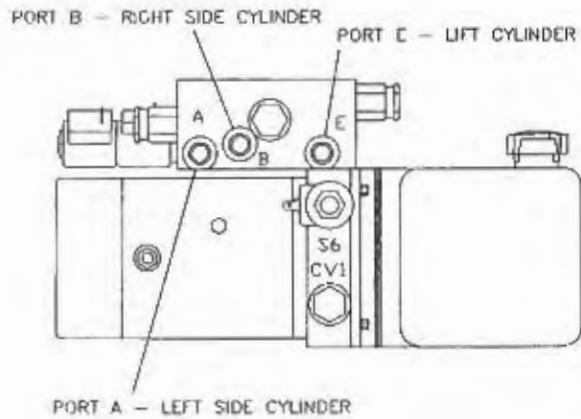
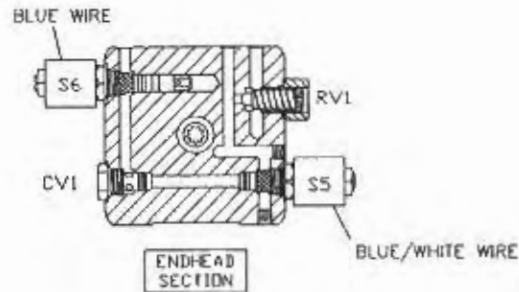
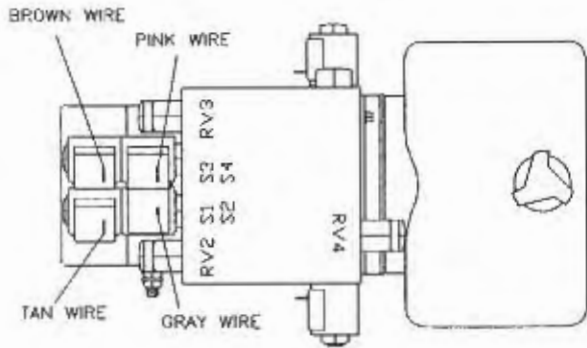

- RV1 - RELIEF VALVE, SYSTEM, 2800 PSI
- RV2 - RELIEF VALVE, ANGLE CYLINDERS, 2800 PSI
- RV3 - RELIEF VALVE, ROLL OVER CYLINDER, 3000 PSI
- RV4 - RELIEF VALVE, ROLL OVER CYLINDER, 3200 PSI

POWER UNIT HYDRAULIC CIRCUIT DIAGRAM

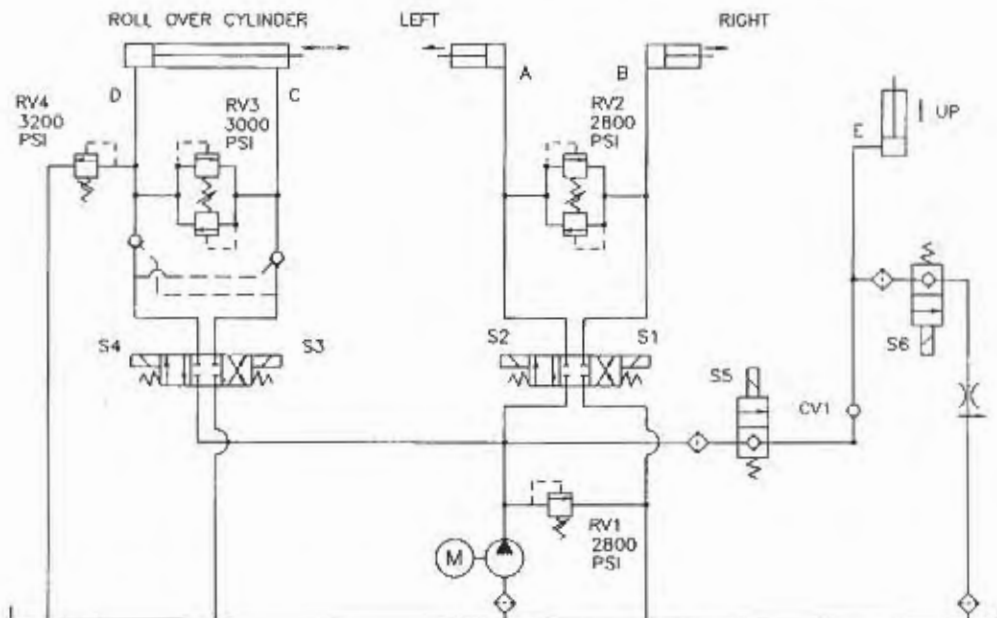

- S1 - RIGHT EXTEND, LEFT RETRACT - TAN WIRE
- S2 - LEFT EXTEND, RIGHT RETRACT - GRAY WIRE
- S3 - CURL - BROWN WIRE
- S4 - UNCURL - PINK WIRE
- S5 - LIFT - BLUE/WHITE WIRE
- S6 - LOWER - BLUE WIRE

HINIKER WARRANTY

The only warranty Hiniker Company (Hiniker) gives and the only warranty the dealer is authorized to give is as follows:

We warranty products sold by Hiniker or authorized Hiniker dealers to be in accordance with our published specifications or those specifications agreed to by us in writing at time of sale. Our obligation and liability under this warranty is expressly limited to repairing or replacing, at our option, within one year after date of retail delivery, to the original purchaser, any product not meeting the specification. **WE MAKE NO OTHER WARRANTY, EXPRESS OR IMPLIED AND MAKE NO WARRANTY OF MERCHANTABILITY OR OF FITNESS FOR ANY PARTICULAR PURPOSE.** Our obligation under this warranty shall not include any transportation charges or costs or any liability for direct, indirect or consequential damage or delay. If requested by Hiniker Company, products or parts for which a warranty claim is made are to be returned freight prepaid to our factory. Any improper use, operation beyond rated capacity, substitution of parts not approved by Hiniker Company, or any alteration or repair by others in such manner as in our judgment affects the product materially and adversely shall void this warranty. **NO EMPLOYEE OR REPRESENTATIVE IS AUTHORIZED TO CHANGE THIS WARRANTY IN ANY WAY OR GRANT ANY OTHER WARRANTY.**

HINIKER reserves the right to make improvement changes on any of our products without notice.

HINIKER does not warrant the following:

1. Used products.
2. Any product that has been repaired, modified or altered in a way not approved by Hiniker Company.
3. Depreciation or damaged caused by normal wear, lack of reasonable and proper maintenance, failure to follow Operator Manual Instructions, misuse, lack of proper protection during storage, or accident.
4. Parts replacement and service necessitated by normal wear or maintenance including, but not limited to, any ground engaging components.

A DELIVERY REPORT FORM must be filled out and received by **HINIKER COMPANY** to initiate the warranty coverage.

HINIKER COMPANY
58766 240th St.
P. O. BOX 3407
MANKATO, MN 56002-3407
PHONE (507) 625-6621
FAX (507) 625-5883
www.hiniker.com

[REDACTED]